



**NATIONAL COFFEE RESEARCH, DEVELOPMENT AND EXTENSION CENTER**

**FABRICATION OF UNMANNED GROUND VEHICLE**  
**MATERIALS AND LABOR – 2<sup>ND</sup> POSTING**

**ABC: Php 1,300,000.00**

**Funding Source: TRUST (PCAARRD UGV/UAV vis-NIR Project)**

Item No.	Qty./ Unit	Item Description	Unit Price (Php)	Total Price (Php)
1	1 lot	Fabrication of Unmanned Ground Vehicle (Materials and Labor)	1,300,000.00	1,300,000.00
			<b>Total Amount</b>	<b>1,300,000.00</b>

\*With on-site presentation/ demonstration before acceptance, and user training prior to final acceptance of the product. Must have at least one (1) year of calibration and preventive maintenance services and at least a two-year warranty on parts and services.

**Components/ List of Materials**

Qty/Unit	Item Description
1 lot	Unmanned Ground Vehicle Chassis and Structural Parts
2 units	Custom Battery (Lifepo4 24V 40AH/50AH), Length<260mm, Width<170mm, Height<200mm
12 units	Pillow Block (19.05 mm or 3/4 Inch)
4 units	Heavy-Duty Linear Actuator (12V, 1200 N, 10mm/sec, 250 mm/10" Stroke)
2 units	Linear Guide Rail 1000 mm Length with Bearing Block
1 unit	Linear Actuator (Electro-Hydraulic, 300 mm Stroke)
1 unit	Cordless Electric Earth Auger Drill 20V
2 units	Nema 23 Stepper Motor with Worm Gear (113 mm, 30:1 gear ratio)
2 units	Flexible Jaw Coupling 40x66mm 14mm - 19mm
2 units	Motor Driver for Nema 23
2 units	Geared Stepper Motor Shaft
2 units	Nema 23 Bracket
2 units	Ball Screw Linear Guide Actuator with Nema 23 Stepper Motor 100 mm Stroke
1 unit	Roller Chain (12B-1 Simplex Roller Chain, 5m)
2 units	BLDC Geared Motor with Controller (750 watts, 460 rpm)
4 units	Wheel 145/70-6 three-hole Assembly
6 units	Sprockets and Chain Set (#420 - 28T - 14T - 70L)
4 units	Sprockets and Chain Set (#420 - 25T - 14T - 70L)
2 units	Viper-Slide Kit 2 Stage (Belt-Driven, 336mm Slides)
2 units	Planetary Gear Motor (99.5:1 Ratio, 60 RPM, 3.3 - 5V Encoder)
1 unit	U-Channel 1121 Series Low-Side (15 Hole, 384mm Length)
1 unit	ServoBlock (Standard Size, 25 Tooth Spline, Hub-Shaft)
1 unit	Servo Travel Tuner

1 unit	Servo Dual Mode 2000 Series (25-2, Torque, 300:1)
1 unit	1804 Series Servo Stand (32-1)
1 unit	10mm Bore Face Thru-Hole Pillow Block (32mm x 32mm Mounting Pattern)
1 unit	Servo Hub-Shaft 1910 Series (25 Tooth Spline, 10mm Shaft Diameter, 33mm Length)
2 units	Pillow Block 10mm Bore Face Thru-Hole (32mm x 32mm Mounting Pattern)
1 unit	Socket Head Screw (M4 x 0.7mm, 10mm Length) - 25 Pack
1 unit	Socket Head Screw (M4 x 0.7mm, 18mm Length) - 25 Pack
1 unit	Socket Head Screw (M4 x 0.7mm, 25mm Length) - 25 Pack
2 units	Flexible Jaw Coupling (40x66mm 14mm - 19mm)
2 units	Motor Driver for Nema 23 ( 1.0-4.5A 18-50VDC)
2 units	Motor Shaft (14mm diameter, 102 Length)
2 units	Sprocket (PHS 12B-1BH11 12B-1 Chain Type)
1 unit	Auger Drill Bit (40 mm x 800 mm)

*Note: detailed design is available upon request; supplier/fabricator must sign a confidentiality/non-disclosure agreement before receiving the detailed design*

**SAMPLE PHOTOS**

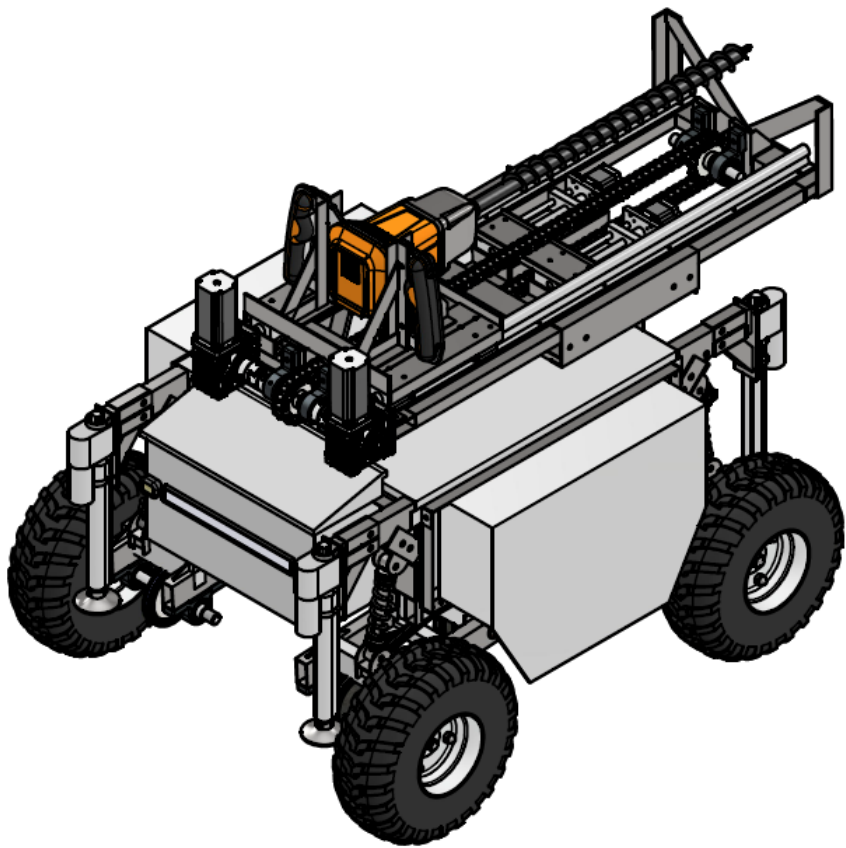

**Unmanned Ground Vehicle (UGV)**

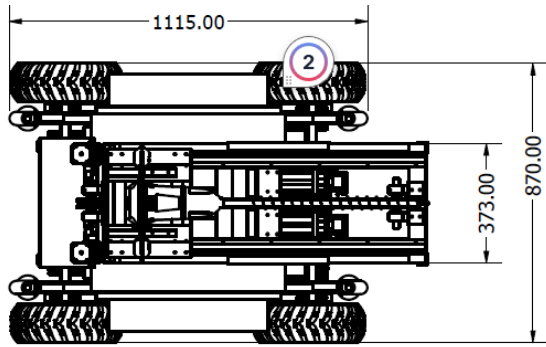

Top View

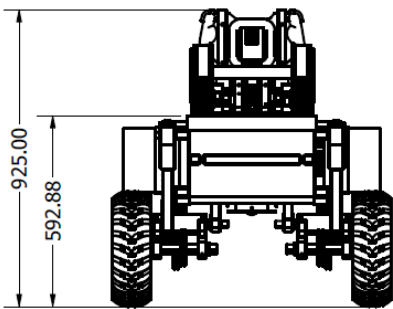
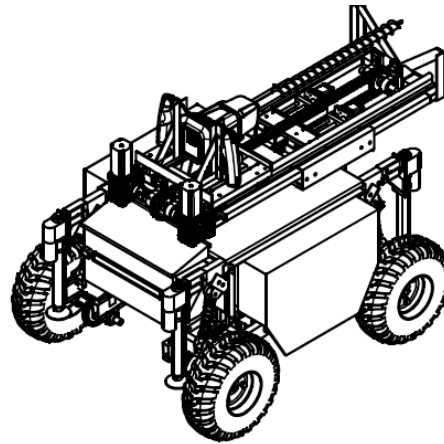

Front View

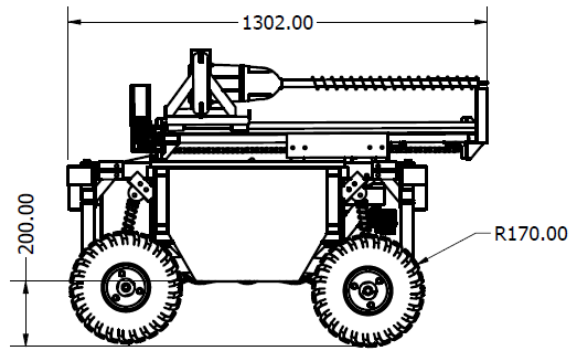

Side View

Scale: 1:15

Prepared by:

*Jesriel Alsonado*  
**JESRIEL Y. ALSONADO**  
 Project Technical Assistant IV

*Rodney B. Javier*  
**RODNEY B. JAVIER**  
 Project Technical Assistant VI

*Al Eugene L. Torres*  
**AL EUGENE L. TORRES**  
 Project Support Staff

Attested by:

*Gerry M. Castillo*  
**GERRY M. CASTILLO**  
 End-User

Noted by:

*Edwin R. Arboleda*  
**EDWIN R. ARBOLEDA**  
 TWG Member, ECE Supplies and Equipment

*Michael T. Costa*  
**MICHAEL T. COSTA**  
 TWG Chair, ECE Supplies and Equipment

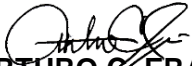

**ARTURO C. ERAÑA**

TWG Member, Transportation and Other Machineries



**EMERSON C. LASCANO**

TWG Member, Transportation and Other Machineries



**RONALD P. PEÑA**

TWG Chair, Transportation and Other Machineries